



FLUID COMPONENTS, INC.

Hydraulic Gear Pump Model GP-F20



Constructed of an aluminium center section and cast iron end plates, model GP-F20 is a high pressure hydraulic gear pump with 11 displacement sizes from 0.24 - 1.95 in³/rev. (4 - 32 cm³/rev). The standard mounting flange is a SAE A - 2 bolt. Standard drive shaft is a 5/8" straight shaft with 5/32" key. Additional shaft options are available as outlined in the Ordering Example.

Recommended working conditions:

FILTRATION: 25 micron or better OIL VISCOSITY: 7 - 700 cSt INLET PRESSURE: 12 - 32 psi absolute
OIL TEMP: -25° - 80°C (-12° - 175°F) AMBIENT -22° - 55°C (-8° - 130°F)

Technical Specifications

Model	Displacement	Pressure psi	Speed rpm		Weight lbs	Ports		L		L1
	in ³ (cm ³) / rev		Rated	Max		In	Out	side ported	rear ported	
GP-F20-04	0.24 (4)	3650	2000	3600	8.30	SAE-12	SAE-10	3.70"	4.15"	1.69"
GP-F20-06	0.36 (6)	3650	2000	3600	8.55	SAE-12	SAE-10	3.87"	4.32"	1.77"
GP-F20-08	0.48 (8)	3650	2000	3600	8.75	SAE-12	SAE-10	3.95"	4.40"	1.85"
GP-F20-10	0.61 (10)	3650	2000	3600	8.80	SAE-12	SAE-10	4.12"	4.47"	1.89"
GP-F20-12	0.73 (12)	3650	2000	3600	9.05	SAE-12	SAE-10	4.25"	4.70"	1.97"
GP-F20-14	0.85 (14)	3650	2000	3600	9.20	SAE-12	SAE-10	4.35"	4.80"	2.00"
GP-F20-16	0.97 (16)	2900	2000	3600	9.35	SAE-12	SAE-10	4.50"	4.95"	2.07"
GP-F20-20	1.22 (20)	2900	2000	3600	9.80	SAE-12	SAE-10	4.72"	5.17"	2.20"
GP-F20-25	1.52 (25)	2900	2000	3600	10.30	SAE-12	SAE-10	5.17"	5.62"	2.36"
GP-F20-30	1.83 (30)	2300	2000	3600	10.75	SAE-16	SAE-12	5.35"	5.80"	2.52"
GP-F20-32	1.95 (32)	2300	2000	3600	11.00	SAE-16	SAE-12	5.79"	6.24"	2.87"

Flow Rate (gpm) = Disp. (in³/rev) X Speed (rpm) / 231
Volumetric efficiency % ≥93

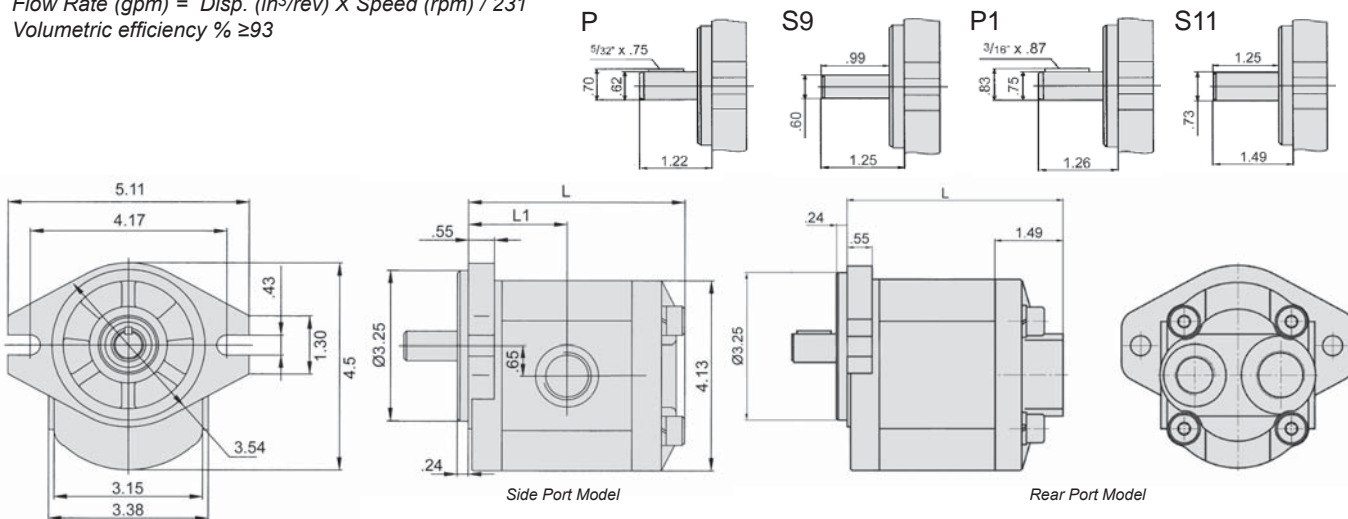

Ordering Example: **GP** - **F20** - **25** - **P** - **C** -

Category	Series	Displacement (see chart)	Drive Shaft*	Rotation	Options
Gear Pump	F20 Series SAE "A" Mount	04/06/08/10/12 14/16/20/25/30/32	P = 5/8" dia. Straight P1 = 3/4" dia. Straight S9 = SAE 9-tooth spline S11* = SAE 11-tooth spline	C = Clockwise A = Counter-Clockwise (viewed from shaft end)	BB** = Rear Ports

* Additional seal and shaft options available. Consult factory.
** Reduced flow for 20cc & 25cc models. Not available on 30cc or 32cc

Seal kits are available for F20 gear pumps. See page 126 for details.