



FLUID COMPONENTS, INC.

High Pressure Series Needle Valve

Features

- Rated up to 10,000 psi at 200°F
- Zinc-nickel plated steel body with 316SS stem
- Blow out proof stem
- Slotted spring pin prevents accidental loosening

Dimensions for 1/8" Valves

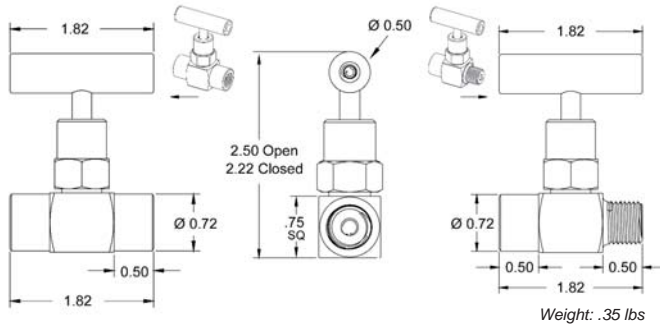

Dimensions for 1/4" - 1 1/2" Valves

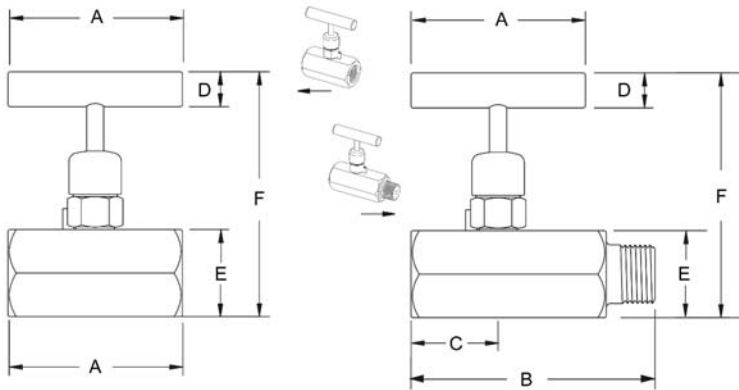

The HPNV series of high pressure needle valves replaces the DFFG series which we previously offered. A quick cross reference is provided below.

Old Part #	New Part #
DFFG2001T	HPNV-1/8NPT-FF
DFFG2002T	HPNV-1/4NPT-FF
DFFG2003T	HPNV-3/8NPT-FF
DFFG2004T	HPNV-1/2NPT-FF
DFFG2006TA	HPNV-3/4NPT-FF
DFFG2008TA	HPNV-1NPT-FF

Valve Size	A	B	C	D	E	F		Weight
						Closed	Open	
1/4" - 1/2" NPT	2.5"	3.5"	1.25"	Ø 0.5"	1.25" Hex	3.50"	3.78"	1.10 lbs
3/4" - 1 1/2" NPT	4.25"	5.25"	2.125"	Ø 0.75"	2.25" Hex"	4.75"	5.50"	5.20 lbs

Ordering Example:

Model: **HPNV** - Size: **1 NPT** - Connection: **FF**

Model	Size	Connection
HPNV	1/8 NPT	3/4 NPT
	1/4 NPT	1 NPT
	3/8 NPT	1 1/4 NPT
	1/2 NPT	1 1/2 NPT